



SPARTAN TOOL

FOR TOUGH CUSTOMERS. SINCE 1943.



SPARTAN REVOLUTION M2

powered by 

Spartan Tool LLC | 1618 Terminal Road | Niles, MI 49120
order by phone **800.435.3866** | order online **SpartanTool.com**

© 2026 Spartan Tool LLC
Part #3540000817ST
3540001817ST



Contents

SAFETY INFORMATION	4
Environment	6
Transport.....	6
Storage.....	6
Disposal.....	6
GENERAL INFORMATION	7
Intended Use	8
Available Tooling	8
TECHNICAL INFORMATION	8
SAFETY FEATURES	9
Voltage.....	9
Power Plugs	9
Safety Features	9
Noise Levels, Vibrations & Emissions	10
CE DECLARATION OF CONFORMITY	11
Before Operation	12
During operation	12
Starting & Using the Machine	12
OPERATING INSTRUCTIONS	12
Attaching Tooling.....	13
Tightening Set Screws	13
Sleeve in DN50 (2") Bends.....	13
ROTATION SPEED DIAL	14
MAINTENANCE	15
Warranty Periods	15
Replacing Carbon Brushes	16
Replacing Safety Clutch Spring.....	19
Inspecting Flexible Shaft for Damage.....	20
Servicing the Flexible Shaft & Outer casing	21
Changing the Flexible Shaft.....	21
Flexible Shaft Extension.....	21
PRODUCTS	22

ACCESSORIES, SPARE PARTS & SERVICE TOOLS	23
Spare Parts	23
Service Tools	23
Cutting The Flexible Shaft	24
Cutting The Outer Casing	24
Shaft Rounder	24
PRACTICAL TIPS & SAFETY ADVICE	24
Sleeve	25
Creating Leaders	25
Adding a Visual Safety Marker	25
REVOLUTION M2 +C 8/16	26
+C CAMERA KIT INSTRUCTIONS	27
Before Operation	27
Screen Icons	27
+C CAMERA FUNCTION GUIDE	28
+C CAMERA TECHNICAL DATA	29
Revolution M2 +C Update Kit	30
Spare Parts	30
+C CAMERA ACCESSORIES & SPARE PARTS	30
TROUBLESHOOTING FLOWCHART	31
TRAINING	32
WARRANTY INFORMATION	33



Safety Information



WARNING: This section contains important safety information. Failure to comply could result in serious injury or death.

SAFETY SYMBOLS

Safety symbols are used throughout this manual to draw attention to potential hazards.



Danger risk of serious injury, follow instructions.



Danger risk of serious injury or death by electrocution, follow instructions.

Danger
Electric shock risk



Danger risk of serious injury from moving parts, follow instructions.



Danger risk of serious injury from hot parts, follow instructions.



Danger do not touch. Risk of injury, follow instructions.

PERSONAL PROTECTIVE EQUIPMENT (PPE)

Always use Personal Protective Equipment including suitable protective clothing, footwear, plus:



Suitable eye protection to protect against injuries and chemicals from irritating eyes.



Suitable ear protection to protect against injuries and chemicals from irritating eyes.



Suitable heat and cut-resistant gloves to help prevent any hand injuries.
Any open injuries or skin irritations should always be covered to avoid contact with sewage, chemicals or dust.



Suitable respirator to prevent any dust or fumes being inhaled or consumed, which could cause occupational asthma or dermatitis.

GENERAL MACHINE SAFETY INFORMATION



WARNING: This section contains important safety information. Failure to comply could result in serious injury or death.



1. Always wear eye and ear protection as well as heat and cut-resistant gloves.
2. Always ensure that the machine is fully turned off and unplugged before inspection, maintenance, or installing any accessories to the machine. Always follow the instructions in the manufacturer's manual.
3. Before each use inspect Revolution and shaft carefully for any potential damage. Change damaged parts immediately.
4. Ensure the pipe has been opened and ventilated to prevent any gases accumulating.
5. Dust produced when working can be dangerous to your health, inflammable or explosive. Make sure that the job location is well ventilated before grinding or drilling. Always use a vacuum extraction system in the pipe to remove dust. The operator must wear a dust mask when using dry grinding to clean pipes.
6. If the working environment is extremely hot and humid, or badly polluted by conductive dust, use a GFCI-enabled power outlet to increase operator safety.
7. Ensure that the Revolution ventilation openings are kept clear when working in dusty conditions to avoid damaging internal parts. If it should become necessary to clear dust, first unplug the machine.
8. When in use, it is very important that the machine is stable and on an even surface at all times.
9. Never leave the machine running unattended.
10. Always hold the shaft when operating the machine.
11. Never touch rotating parts.
12. Do not touch the tooling immediately after use, it may be hot and could burn skin.
13. Do not use on any pipes containing asbestos fibers.
14. Do not stand on the machine.
15. Only operate the foot pedal (OPC) as instructed. Never place anything on it in place of the operator's foot.
16. Only use the Revolution with the accessories and spare parts offered by the Picote Solutions. Accessories and spare parts should only be used in the manner intended and as described by Picote Solutions.
17. Do not use the Revolution M1 or Revolution M1 +C with an extension.

Safety Information

ENVIRONMENT

- **Operational Ambient Temperature Range:** 14°F to 122°F (-10°C to 50°C), frost and condensation free.
- **Storage Ambient Temperature Range:** -4°F to 140°F (-20°C to 60°C), frost and condensation free.
- **Maximum Altitude:** 2000m or 6500 ft. Derate above 3280 ft (1000m): 328 ft (1% / 100m).
- **Maximum Humidity:** 95% non-condensing.
- **Camera Maximum Humidity:** 90% non-condensing.

TRANSPORT

Revolutions should be transported laid down and secured with ratchet straps to prevent any sudden movements or accidents caused by hard braking or an accident.

Never transport with tooling attached to the shaft. Always retract camera back into housing during transport.

If using a pick-up or trailer to transport, always suitably cover the machine to protect it from the elements.

STORAGE

It is recommended that Revolutions be stored indoors to protect them from rain and sunlight, and also in a constant ambient temperature. The best way to store the Revolution is using the original box that it was shipped in.

If the Revolution has been stored in an environment colder than +10°C or 50°F, it should be stood at room temperature for 24 hours before use.

If the Revolution has been stored for long periods of time (over 2-3 months), it should be checked and tested according to the maintenance program before use.

+C versions: Charge DVR battery fully before storing for long periods. NEVER leave DVR unit unattended while it is charging.

DISPOSAL

The Revolution motor, control box, electric wires, axle package including slip ring, camera monitoring box, power supply and camera head can be disposed in Europe at Waste Electrical and Electronic Equipment (WEEE) collection points.

The Revolution frame, reel, flexible shaft, camera cable reel and name plate can be recycled in metal waste collection points.

Shaft outer casing and camera plastic supports can be disposed of as plastic waste.

The +C camera monitoring box includes a Li-ion battery. Recycle Li-ion batteries according to regulations. Do not dispose of in fire! Do not puncture!

Always follow all local, regional, and national waste handling rules and regulations for disposal.



Li-ion



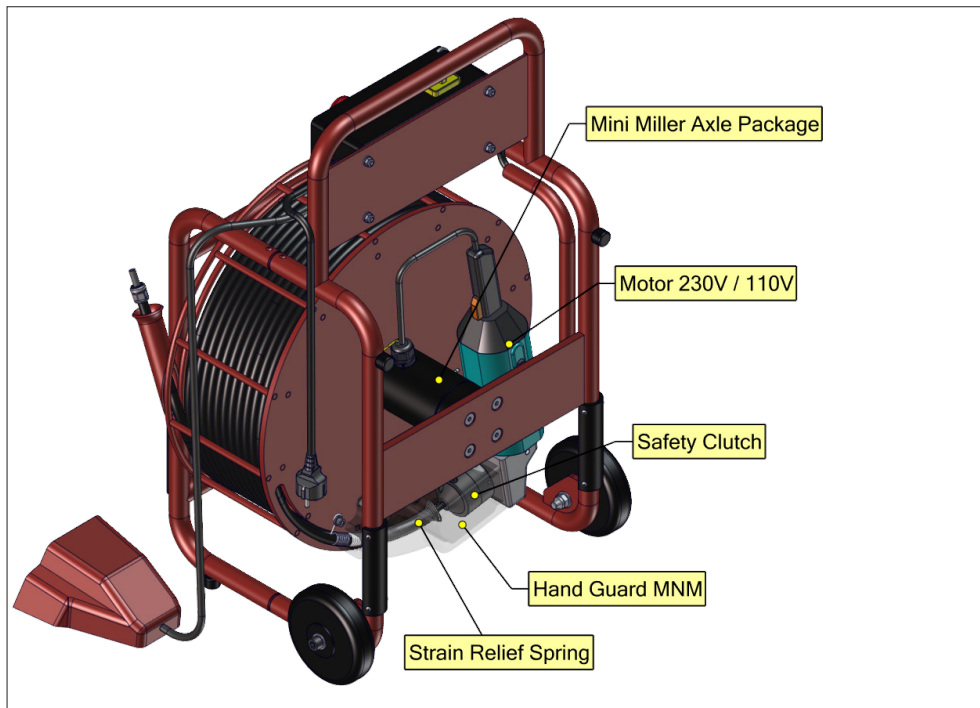
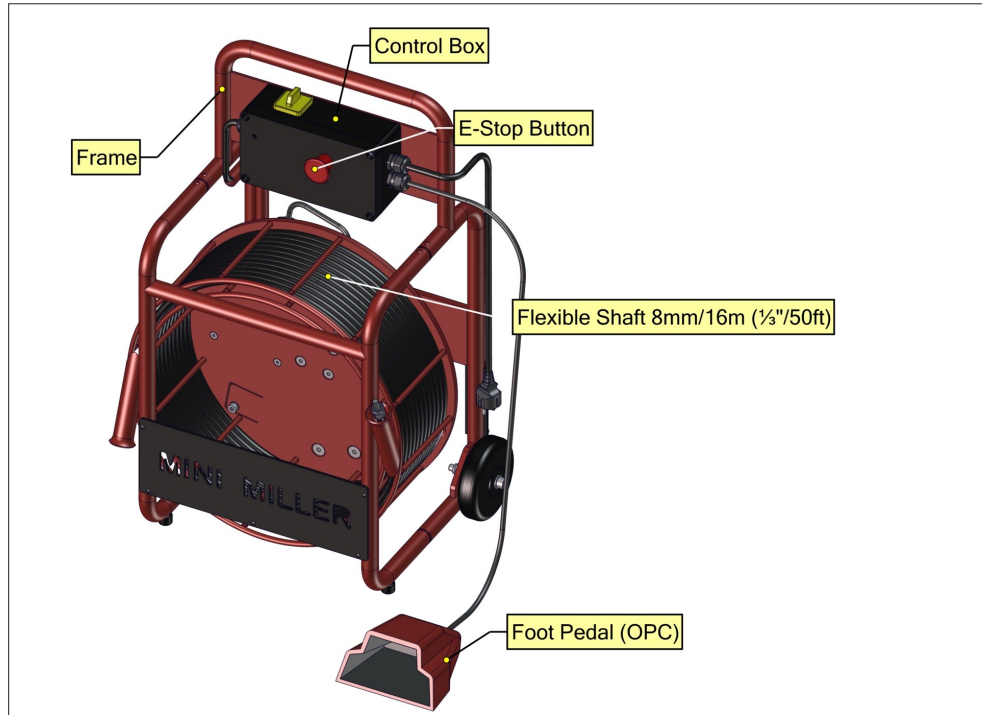

CAUTION: When in use always lay the machine down horizontally on the floor. When not in use some non-hazardous Picote Flexible Shaft Lubricant might leak from the hand guard.



Technical Information

SIZE	SHAFT	RANGE	PIPE DIAMETER	ROTATING SPEED	OUTPUT (W)	POWER SOURCE	WEIGHT
740 x 519 x 404 mm (29 x 20 x 16")	8 mm (1/3")	16 m (50')	DN50-100 (2-4")	500-2900 rpm	110V:1100	Electric Motor	27 kg (60 lbs)

INTENDED USE

1. Cleaning, descaling, and unblocking pipes, drains and sewers.
2. Reinstating CIPP lined connections by drilling/cutting and grinding.
3. Internal pipe coating using the Picote Brush Coating System™.

Always follow the Picote Solutions instructions when installing and using the machine with tooling and accessories.

AVAILABLE TOOLING

Original Chains	Cyclone Chains	3D Chains
Smart Cutter™	Nylon Cleaning / Coating Brush	Mini Sweeper
Special Drill Head	Wire Brush	Twister Mini
Tiger Bore	Tiger Drill Chains	

Please check Picote Solutions Quick Guides and Tool Manuals for more detailed information: www.picoteinstitute.com.



VOLTAGE

Ensure that the supply voltage is correct. The voltage of the power source must match the value given on the nameplate of the machine within the tolerances of $\pm 10\%$. Machines with a 230V plate can be used in 220V mains and 110 machines in the 120V grid.

The machine has been double sealed according to European standards. The power source has to be grounded.

Camera power supply can operate with Input: 110VAC ~ 240 VAC, Output: 12V DC 1200mA.

The DVR unit has in-built 5200 mAh Li-ion battery (7.4V).

POWER PLUGS

For safety purposes only use grounded outlets. If the plug does not fit securely or match the outlet do not force it — contact an electrician to determine required power supply. Never alter the plug in any way.

Use a heavy duty, appropriately gauged extension cord that can be fully inserted into the receptacle.

If a power generator is used as power source ensure that the power rating is sufficient.

110-125V: The Revolution M2 and Revolution M2 +C is equipped with a 15 amp (125V) NEMA 5-15 plug. Power cable lead minimum thickness 2,5 mm² / 14 AWG. The Revolution M2 and Revolution M2 +C must be supplied with sufficient power and proper current rating. A minimum of 15A is needed to operate it safely and efficiently. When used with an extension cord, the cord must be a 3 prong, 16A (125V). If power generator is used, minimum 3 kW required. Adapters may be necessary for generator connections. Contact your Reseller or Picote technical support for more information.

SAFETY FEATURES

This machine is equipped with an Emergency Switch Off Button.

The power supply to the motor is cut off when the Emergency Switch Off Button is pushed. Always make sure the Emergency Switch Off Button is pressed or completely unplug the machine when the machine tooling and accessories (e.g. Cutter or Chains) are not inside a pipe. Always engage the Emergency Switch Off Button and unplug the machine from the power source when performing any maintenance or repairs to the machine.



The machine is operated by a Foot Pedal Operator Presence Control or 'OPC'. When the foot pedal is not held down, the machine stops. Never place any kind of object on the pedal in place of the operator's foot (such as a brick).

Safety Features



The typical A-weighted noise level determined according to EN60745:

Sound pressure level (LpA): 90 dB (A)

Sound power level (LWA): 103 dB (A)

NOISE LEVELS, VIBRATIONS & EMISSIONS

Wear Ear Protection:

Emissions during actual use of the machine can differ from declared values depending on the ways that the machine is used. Safety measures to protect the operator should be determined by actual conditions, taking into account all aspects of the operating cycle (such as when the machine is switched off and when it is running idle).

Vibrations:

Hand vibration levels depend on the distance from the tool head to the user and working conditions. The vibration levels detailed below have been measured at the Picote training facilities in Finland.

Vibration has been determined according to ISO-5349 and EU-directive 2002/44/EG.

Safe daily exposure time for user:

Exposure Action Value (EAV) 2,5 m/s²

Exposure Limit Value (ELV) 5,0 m/s²

TOOLING	WORKING DISTANCE (M/FT)	EAV	ELV
Mini Twister DN50 (2")	2m (6.6 ft)	10h 14min	Over 24h
Mini Twister DN50 (2")	10m (32 ft)	Over 24h	Over 24h
Original Cleaning Chain DN50 (2")	0-2m (0-6.6 ft)	9h 42min	Over 24h
Original Cleaning Chain DN50 (2")	0-15 (0-49 ft)	16h 42min	Over 24h

Due to continuing product development, the specifications herein are subject to change without notice.

CE Declaration of Conformity



We Picote Solutions Oy Ltd as the responsible manufacturer, declare that the following Picote Solutions Oy Ltd drain cleaning machine:

Mini Miller

Model No: 8/16

and

Mini Miller +C

Model No: 8/16

are of series production and

Conform to the following EU Directive:

2006/42/EY

And is manufactured in accordance with the following standards or standardised documents:

EN62841-1

EN62841-3-14

ISO-5349-1:2001

The technical documentation is kept by our authorised representative in Europe who is:

Picote Solutions Oy Ltd, Pienteollisuustie 24
06450 Porvoo, Finland

31st July 2020

A handwritten signature in black ink, appearing to read 'Katja Lindy-Wilkinson'.

Katja Lindy-Wilkinson
C.E.O.

Picote Solutions Oy Ltd
Pienteollisuustie 24, 06450 Porvoo, Finland



Operating Instructions

BEFORE OPERATION

Before installing Picote tools, always make sure that the machine is fully turned off and unplugged.

Always round off the sharp edges of the shaft to avoid cuts and to make it easier to insert the shaft into the tool or for a leader to be used.

Check that there is the correct length of flexible shaft (without its outer casing) exposed and that all screws have been loosened so that the shaft can be easily inserted completely inside the tooling. Position the shaft inside the tooling, as far as it will go, and tighten the screws. Consult accessory tooling manuals for detailed information.

DURING OPERATION

Always lay the machine down horizontally on the floor. During drilling, grinding and cutting processes, always use a separate vacuum extraction system or run water in the drain to remove dust.

STARTING & USING THE MACHINE

1. Machine has an Operator Presence Control Foot Control Pedal or 'OPC'. The machine will only run when the foot pedal is pressed/held down.
2. Machine can also be stopped by pushing the Emergency Stop Button down, rotating the power gear to "O" or unplugging the machine.
3. The control of the rotational speed is located on the Buffer Motor (underneath the machine) The rotational speed increases when the control is turned to higher numbers.
4. Place the tooling inside the pipe.
5. Turn on the power switch.
6. Release the Red Emergency Switch Off Button.
7. The machine starts when the OPC foot pedal is pressed down.
8. Always hold the shaft with both hands firmly while operating the machine.
9. Rotating the tooling slowly makes it easier to move forward inside the pipe.
10. The lifespan of the shaft outer casing can be prolonged by using a Sleeve Bearing designed for the outer casing.
11. Mechanical Safety Clutch:
 - There is a mechanical safety clutch installed in Revolution M2.
 - If the machine is overloaded the safety clutch separates the shaft from the motor.
 - User will hear a loud noise when this happens.
 - Release the foot pedal, pull the shaft back a little bit and continue working.
 - If the safety clutch is released constantly the silicone spring inside of it may have worn down.
 - See the Safety Clutch Spring Change instructions in this manual to change the spring.
 - Avoid overloading the motor.

ATTACHING TOOLING

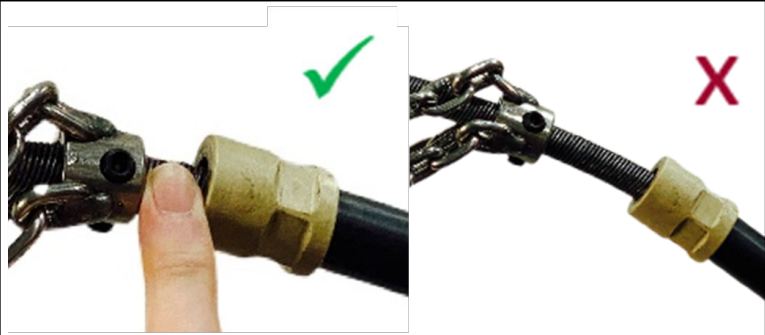

Keep the gap between the Sleeve and the Tool to 6mm (1/4")



SLEEVE

TIGHTENING SET SCREWS

When you add tooling, always tighten the set screws starting from the screw furthest away from the end of the flexible shaft (where applicable).



SLEEVE IN DN50 (2") BENDS

Depending on the type of bend you may not be able to easily navigate a DN50 (2") bend unless you first remove the Sleeve. This is usually the case for tight bends (see examples to the right).



Depending on the type of bends used on DN50 (2") pipe you may have to remove the Sleeve



Rotation Speed Dial

The optimal rotation speed of the Revolution M2 and Revolution M2 +C is between 2-4 (900-2100 rpm) depending on the work. Minimum rotation speed is usually preferred when moving the tool around tight bends. When beginning work adjust the speed up to the level which seems to work the best.

Do not use a rotation speed higher than setting 4 (2100 rpm) as it may cause overheating between shaft & outer casing.

The speed dial can be found on the motor itself (see image right). Set the speed by rotating the button. Check the corresponding rotation speed from the table below.



ROTATION SPEED	SPEED DIAL
3200	X
2700	X
2100	X
1500	X
900	X
600	X
	1 2 3 4 5 6

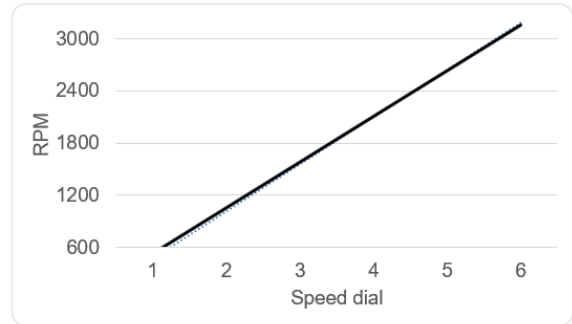



MAINTENANCE TASK

MONTHS

3 6 12 24

MAINTENANCE TASK	3	6	12	24
Change motor carbon brushes			I	R
Tightness of motor attachment			I	I
Alignment of motor			I	I
Condition of frame			I	I
Condition of wheels & rubber feet			I	I
Condition of Control Box			I	I
Condition of electric cables	I	I	I	I
Condition of electrical connections	I	I	I	I
Lubricate Shaft	P	P	P	P
Operation of E-stop	I	I	I	I
Safety Clutch Silicone Ring	I	I	I	I
Operation of Safety Clutch	I	I	I	I

I: Inspect, fix, or replace if needed.

P: Perform, replace if needed.

R: Replace

WARRANTY PERIODS

Picote Solutions grants limited warranty for certain machines, equipment & components.

Read more detailed information in the Picote Warranty Policy and Procedure section.

SERVICE PERIOD	3 MONTHS	6 MONTHS	1 YEAR
A	[Green bar covering 3, 6, and 12 months]		
B	[Yellow bar covering 3 and 6 months]		
C	[Orange bar covering 3 months]		
A	Milling machine & spare parts, except;		
B	Electric motors		
C	Service Center repair work		

Maintenance

1. Before performing any maintenance always check that the machine is fully turned off and unplugged.
2. Always inspect the flexible shaft before each use. If there are potential weak points, or the shaft is damaged, cut off the damaged length using a band saw or replace the entire shaft as needed.
3. For safety and efficiency, always keep the machine and its motor, drive unit, ventilation and cooling slots clean.
4. Remove handguard and check that the screws for the shaft socket are securely tightened (weekly).
5. Check that all the bolts and screws on the machine are securely tightened.
6. It is recommended that the oil in the angle gear should be changed about every 12 months. Only use regular oil developed for gearboxes.

REPLACING CARBON BRUSHES

Remove and check carbon brushes regularly and replace when worn down to the limit mark. See Maintenance Task schedule for maintenance intervals. Keep the carbon brushes clean and free to slip in the holders.

Both carbon brushes should be replaced at the same time. Use only identical carbon brushes.

Newer Revolution M2 have a maintenance hole for carbon brush changing. Skip to step 4.

Maintenance Hole

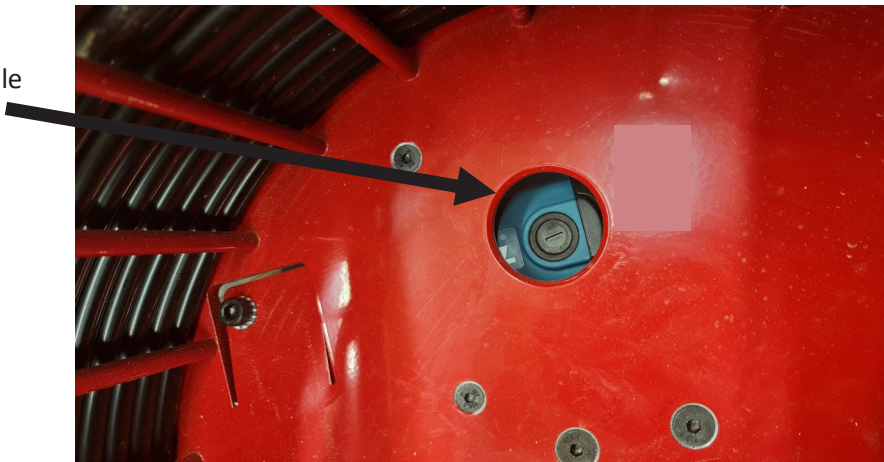

For older versions the complete motor needs to be removed in order to change both of the carbon brushes.

Follow the steps shown below:

- Use a screwdriver to remove the brush holder caps.
- Take out the worn carbon brushes, insert the new ones and secure the brush holder caps.

1. Remove Allen Bolts and remove the hand guard.

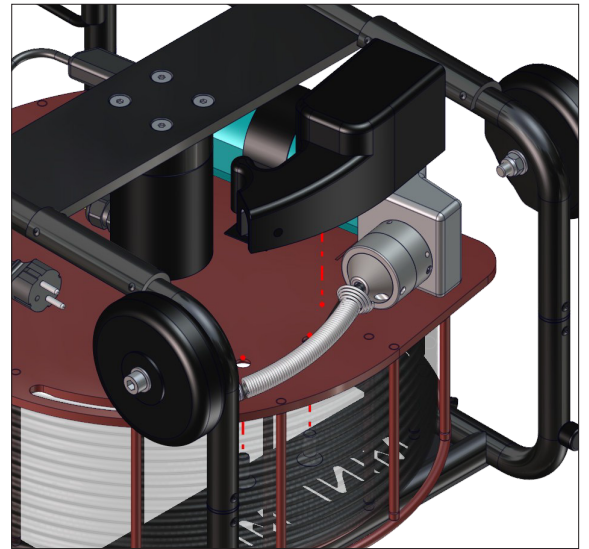

2. Remove Set Screws & detach shaft from Safety Clutch.

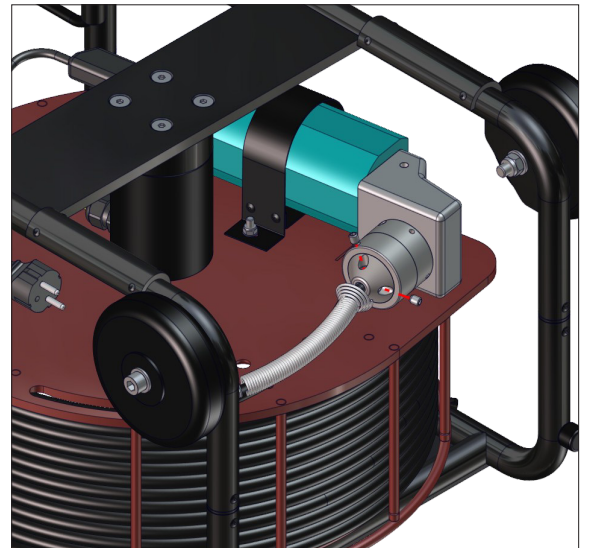

3. Remove Allen Bolts which attach motor to the reel.



Maintenance

4. Open the protective caps with a screwdriver and replace both of the carbon brushes. Repeat the steps in opposite order to reassemble. Tighten the Hex Bolt M8x25 which is attaching the motor to the reel in torque of 12 Nm. Recommended use of Loctite 542

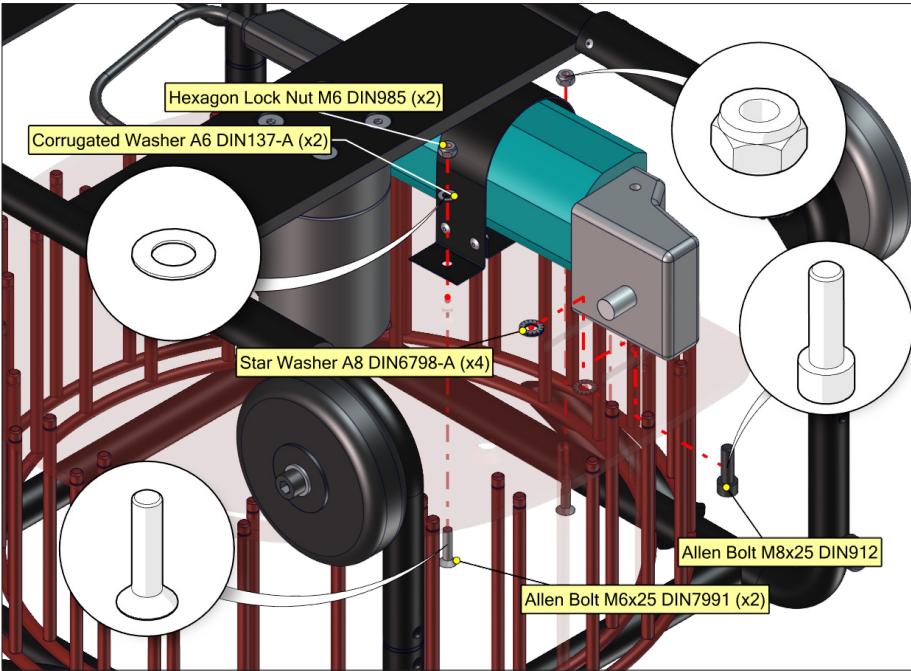
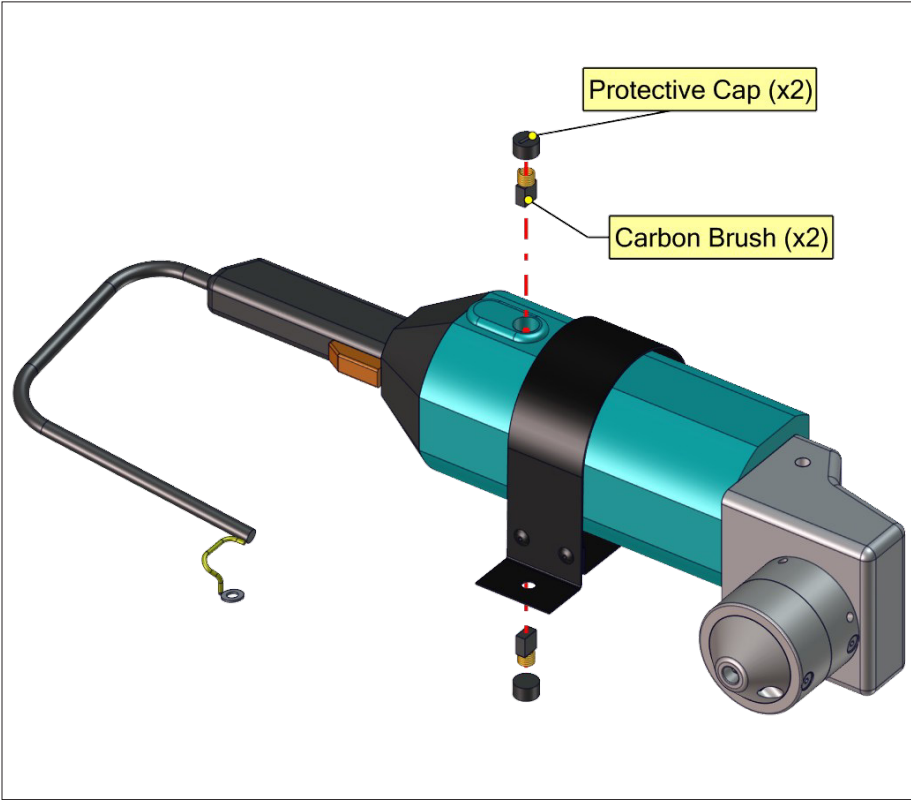

REPLACING SAFETY CLUTCH SPRING

Remove and check the silicone spring of the Safety Clutch regularly and replace when worn down.

When safety clutch begins to release constantly the spring should be changed.

The silicone spring can be easily changed even in field conditions.

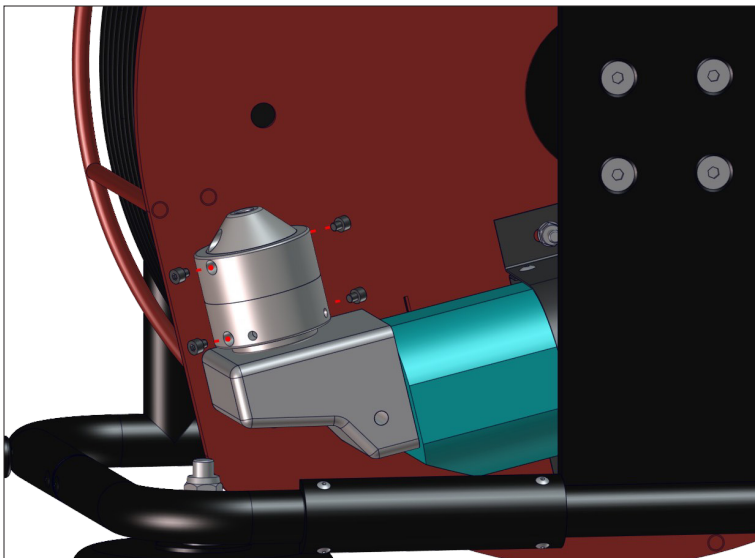

1. Remove the hand guard and detach the flexible shaft from the Safety Clutch.

Open and remove four screws from the Safety Clutch Covers.

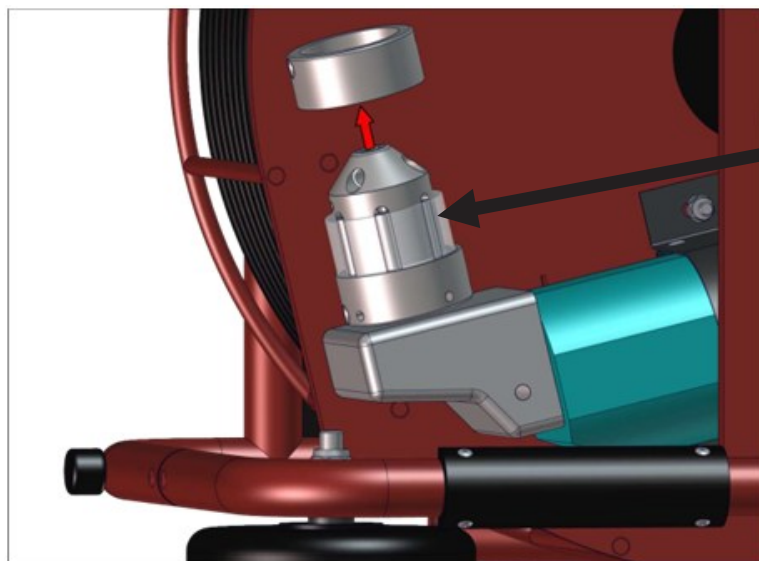

2. Remove the Upper cover and push the Lower Cover down.

NOTE: Silicone spring for Revolution M2 and Revolution M2 +C is white.

The silicone spring for Revolution M1 and Revolution M1 +c is red.

Maintenance

3. Remove the old Silicone Spring and replace it with a new one.

Be careful not to drop axles from heart of the clutch.

Repeat the steps in reverse order.

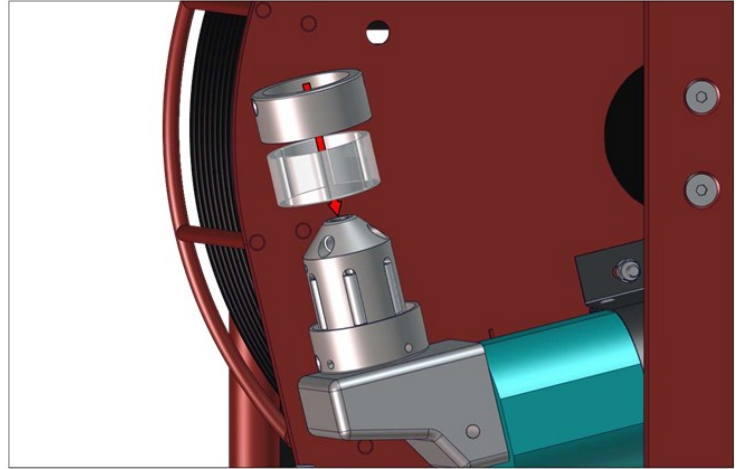

4. The correct way to install shaft into the safety clutch is shown below:

- There should only be 3mm (1/8") in-between the outer casing and safety clutch.
- Push shaft all the way to the end of the safety clutch.
- Recommended: Use of Loctite 542.

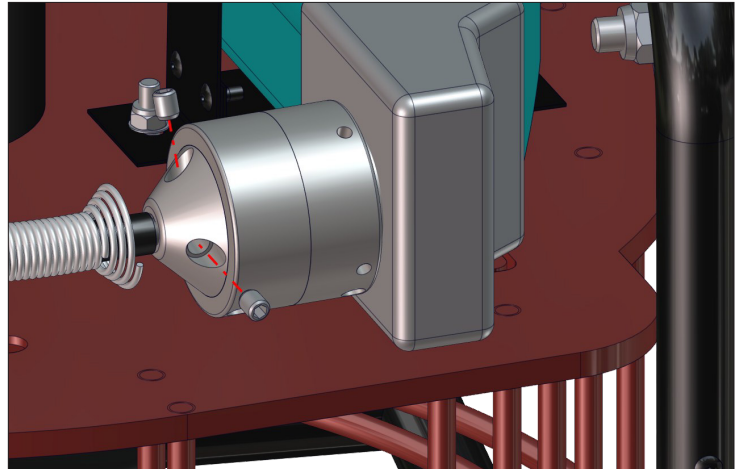

INSPECTING FLEXIBLE SHAFT FOR DAMAGE

Carefully inspect the flexible shaft and its casing on a regular basis to ensure that there are no signs of wear and tear.

Change the flexible shaft and casing when required.

Damaged shaft needs to be trimmed back before attaching tools (see examples to right).

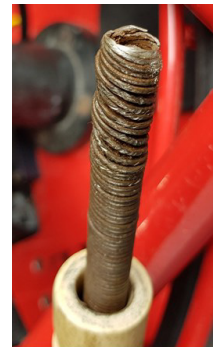

SERVICING THE FLEXIBLE SHAFT & OUTER CASING

The flexible shaft is pre-treated with Picote Flexible Shaft Lubricant and the outer casing replaced prior to shipping. Always inspect the condition of the shaft and its outer casing regularly. Also, inspect at least once a week that the shaft is well attached under the hand guard at the machine end. If the shaft appears to have gaps between the windings from the beginning to the end, the entire shaft will need to be replaced.

In order to add lubricant the shaft needs to be disconnected from the clutch and removed from the reel. The shaft needs to be taken out from outer casing about 1-1,5m (3-5 ft) and lubricant needs to be added on the other side, inside the cavity. No more than 40ml / 40g / 1.4oz will be required for the entire shaft. Too much lubricant can cause a strain on the cable. After the lubricant has been poured, the free shaft end should be pushed through the outer casing. The shaft will push the lubricant evenly inside the outer casing. Connect the shaft to the machine and rotate with low rotation speed so that the shaft will push excess lubricant to the outside. Use a mat to protect the work area under the machine to prevent damage to floors.

Keeping the shaft well lubricated will prolong its life span and decrease the friction caused by the shaft when it turns around. Lower friction will decrease the burden caused to the motor.

If preferred, the shaft can be taken out of its outer casing for lubrication.

Appropriate oil to use: Picote Flexible Shaft Lubricant (available from your reseller)

CHANGING THE FLEXIBLE SHAFT

Only use the shaft and its special outer casing specified by Picote Solutions. Order the replacement shaft from your reseller. The flexible shaft is pre-treated with Picote Flexible Shaft Lubricant and the casing replaced prior to shipping.

1. Loosen bolts holding the hand guard and remove hand guard.
2. Remove bolt holding strain relief spring.
3. Loosen bolts in the safety clutch that hold the shaft.
4. Pull strain relief spring away from the shaft.
5. Pull the old shaft out of the machine.
6. Insert new shaft: Before inserting the shaft inside the safety clutch, add strain relief spring and tighten it. Verify that the shaft goes all the way to the end.
7. Tighten the bolts.
8. Mount the hand guard.
9. Tighten the bolts.

FLEXIBLE SHAFT EXTENSION

Flexible extension shafts are available for the Revolution M2 or Revolution M2 +C in lengths of 10m (32 ft). Do not extend the shaft by more than one extension and only use a Picote shaft extension and connector.

Before attaching or removing the shaft extension always make sure that the machine is fully turned off and unplugged.

1. Operate the machine out as far as possible with the flexible shaft before fitting the extension.
2. Remove the flexible shaft from the pipe.
3. Push the extension down the pipe and then connect onto the existing flexible shaft using a shaft connector.

Note: for vertical pipes connect the extension onto the existing flexible shaft before pushing the extension down the pipe.



Products

Revolution M2

- 1/3" shaft
- Cleaning 2-4"
- Cutting 2-3"
- Coating 2-6"
- Max Range: 50 ft + 32 ft ext
- Weight: 59 lbs
- Speed: 500-2900rpm

The Revolution M2 is a high-speed, high-torque unit designed for cleaning, descaling, and removing roots in 2-4" pipes for cutting/reinstatements in 2-3" pipes. When paired with the Picote Mini coating Pump or Xpress Coating System it is capable of Picote Brush Coating™ in 2-6" pipes as well. Weighing only 59 lbs, its 1/3" shaft has a reach of 50 ft, which can be extended 32 ft by adding a shaft extension. It is fed by a standard 3 prong wall outlet making it very easy to use on almost any job site.

Standard safety features: mechanical safety clutch, operator presence foot control, protective outer shaft casing & E-stop.

PRODUCT #	MODEL
3540000817ST	110V

Revolution M2 +C

- 1/3" shaft
- Cleaning 2-4"
- Cutting 2-3"
- Coating 2-6"
- Max Range: 50 ft + 32 ft ext
- Weight: 69 lbs
- Speed: 500-2900rpm

The Revolution M2 +C features an integrated 98' color camera that makes viewing of cleaning and cutting jobs easier and helps to make Picote Brush Coating™ setup even simpler. Includes two 7/8" color camera heads with 512hz integrated sondes (one self-leveling and one standard). Non self-leveling camera head designed for use during Picote Brush Coating™.

Camera Specs (Self-leveling & Non self-leveling): Head Diameter 7/8", 98 ft cable. 7" color monitor. Lighting: 12 LEDs with brightness control. Digital footage counter. Stainless steel camera head (IP68). Record footage via SD card.

PRODUCT #	MODEL
3540001817ST	110V



SPARE PARTS

1312030085017	Replacement Revolution M2, 8mm (1/3") Shaft, Thick Casing, 17.5m (57.4 ft)
1312030085010	Flexible Shaft 8mm Thick Casing, 10m (32 ft)
9123050001	Shaft Connector 8mm to 8mm (1/3" to 1/3")
93212321085	Sleeve, Thick, 8m (1/3")
9530000134-1	Strain Relief Spring Mini for Safety Clutch
900000856	Revolution M2 Safety Clutch
900000920	Silicone Spring, 5 Pieces (White)

SERVICE TOOLS

Shaft Rounder

1350000018



Rounds sharp edges of the shaft.

Sheath Cutter 1

1350000006



Used when there is no shaft in the outer casing.

Sheath Cutter 2 (Shaft inside outer casing)

1350000011



Used when there is shaft inside the outer casing.

Cutter for Side Grinding Panels

1350000012



Used when there is no shaft in the outer casing.

Hex Keys



PRODUCT

MODEL

1350000008	Hex Key 4mm
1350000009	Hex Key 3mm
1350000010	Hex Key 2.5mm
1350000013	Combo Hex Key 1-6mm

Picote Flexible Shaft Lubricant



Prolong the lifespan of your Revolution with Picote's Flexible Shaft Lubricant. Instructions on maintaining the shaft. Including how to lubricate are included in your Revolution operating manuals.

PRODUCT

MODEL

1350000020	.5L / 16.9 oz Bottle
1350000021	6 Bottle Package



Practical Tips & Safety Advice

Here are some useful tips on how to get the most out of your Picote system.

Always use the recommended tools for maintenance to avoid personal injury.

CUTTING THE FLEXIBLE SHAFT



Always inspect the flexible shaft before each use.

Run the machine briefly in clockwise direction to allow the shaft to return to its natural resting length/position.

If there are potential weak points or the shaft is damaged, cut off the damaged length using a band saw.

For most tools, the shaft should extend ~40mm (1½") past the casing/Sleeve.

Hubs and Original chains without a leader require more exposed shaft.

CUTTING THE OUTER CASING



Always inspect the outer casing before each use.

The easiest and safest way to shorten the outer casing to the correct length is using a sheath cutter.

Only the necessary amount of bare shaft should be exposed at any time.

SHAFT ROUNDER



The Shaft Rounder is used to smooth the end of the flexible shaft, preventing the user from being cut by the otherwise sharp metal edge.



SLEEVE

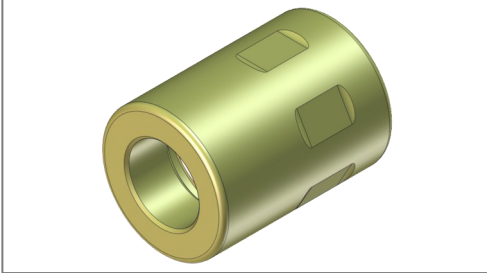

Always use a sleeve when working with the Revolution M2.

It prolongs the life of the flexible shaft and prevents the outer casing from melting in the tool end.

The Sleeve can be reused when the outer casing is shortened.

CREATING LEADERS

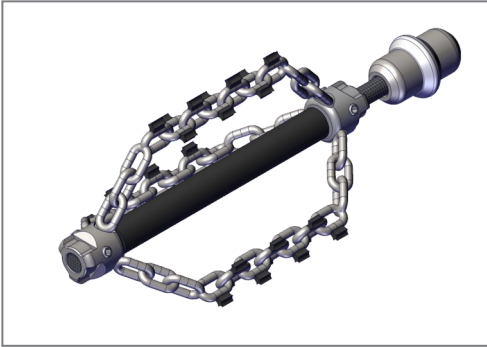

You can extend the life of the flexible shaft and increase productivity by making individual leaders for the most commonly used tools.

This way you easily and quickly switch between tools.

Leaders should always be used if the situation permits it.

ADDING A VISUAL SAFETY MARKER



If not using a "leader" attach a visual marker (tape) on the outer casing of the flexible shaft.

Place it around 500mm (20") from the end of the shaft.

The marker will indicate the tools location and help prevent possible injury from the rotating parts by alerting you when the tool is about to exit the pipe.





Revolution M2 +C 8/16



This machine is intended for the following uses:

1. Tool for inspecting pipes before, during and after work (Navigates through DN50 (2") bends and P-traps)
2. Pipe work as the CCTV camera is fitted with a integrated Sonde (512 hz)

Always follow Picote Solutions instructions when installing and using the machine with accessories.



BEFORE OPERATION

1. Before using +C camera kit, install SD card in SD slot.
 - SD card needing to be 32 GB or smaller.
 - Needs to be a Class 10, High Speed Card.
2. Connect DVR to camera reel with included cable.



SCREEN ICONS

1. SD Card
2. Battery Level
3. Image Reverse
4. Image Reverse & mirror
5. Image Mirror
6. Timestamp
7. LED Brightness
8. Record
9. Meter Counter







+C | Camera Function Guide

1. Live video

Press  to turn on/off the DVR

Press  to start/stop recording



Press  to mirror or/and reverse the image

Press  to adjust the brightness of the camera LEDs

Press  to take a picture

2. Video settings menu

Press  to enter settings menu

Use  and  to navigate in the menu

Press  to confirm the selection

Press  to exit to exit the settings menu

3. Playback menu

Press  to enter playback mode

Use  and  to browse through the files

Press  to confirm the selection and preview media files

Use  and  to preview previous/next file

Press  to playback video

Press  to enter the play settings

4. Playing video

Press  to play/pause the video



Press  to stop playing the video

Press  to rewind

Press  to forward

Press  to change rewind/forward speed

5. DVR settings menu

Press  to enter video settings,
then press  to enter DVR settings



	ITEM	PARAMETER
General	Unit Weight	14Kg (31 lbs)
Camera	Camera Size	ø23mm x 45 mm (Main Body)
	Video Resolution	PAL 720 x 576 25FPS Max. NTSC 720 x 488 30FPS Max
	Front Lens	Sapphire
	Shell Material	304# Stainless Steel
	Lighting	Built-in 12xLED (White)
	Water-Proof	20m (65 ft) Water
	Power Consumption	70 mA (LED OFF), 140 mA (LED ON)
DVR	Screen	17.8cm (7"), 16:9 color LCD screen
	Screen Resolution	800x480 RGB
	Features	Sonde, self-leveling, image mirror, image flip
	External Memory	SD Memory Card up to 32 GB
	Cable Length	30m (100 ft)
	Meter Counter	Yes
	Single Charge Work Time	6 Hours
	Charging Time	8 Hours
Language	English, German, French, Spanish, Italian, Chinese, Japanese, Russian, Portuguese	
Tool Box	Size (L x W x H)	380 x 260 x 150mm (15 x 10 x 6")



REVOLUTION M2 +C UPDATE KIT

3540001000US	Revolution M2 +C Upgrade Kit
--------------	------------------------------

SPARE PARTS

900001754	Revolution M2 +C Camera Head
900001691	+C Charger
900001804	Revolution M2 +C Camera Rod
900001758	Electric Cable +C
900001755	Monitoring Box +C

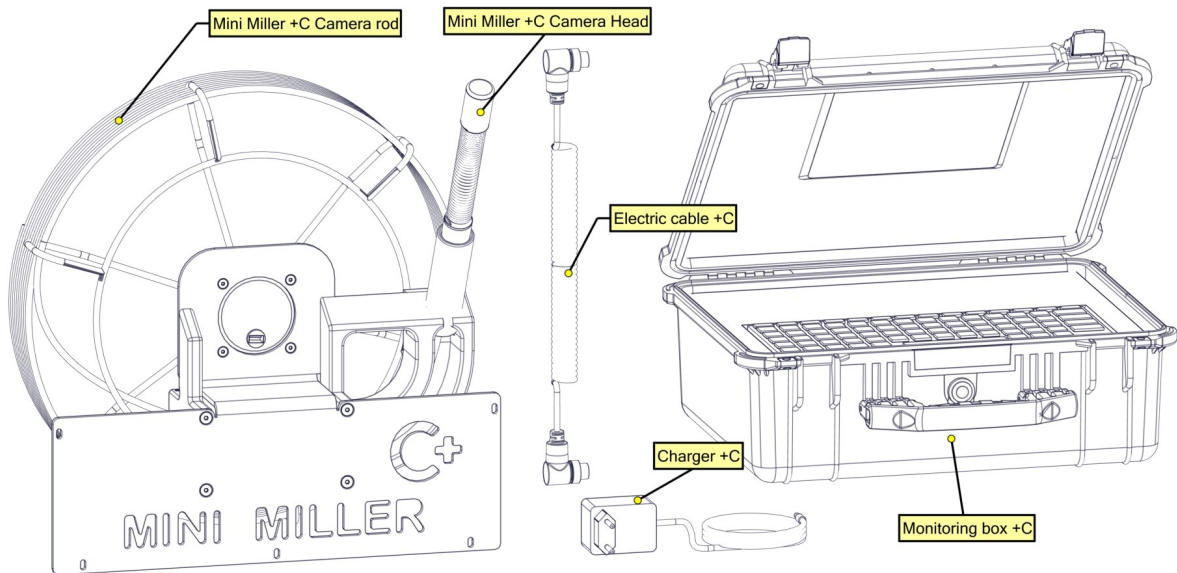

NUMBER (CONFIG)	DESCRIPTION (CONFIG)	QTY
900001758	Electric Cable +C	1
900001804	Revolution M2 +C	1
900001691	Charger +C	1
900001754	Revolution M2 +C Camera Head	1
900001755	Monitoring Box +C	1

Troubleshooting Flowchart

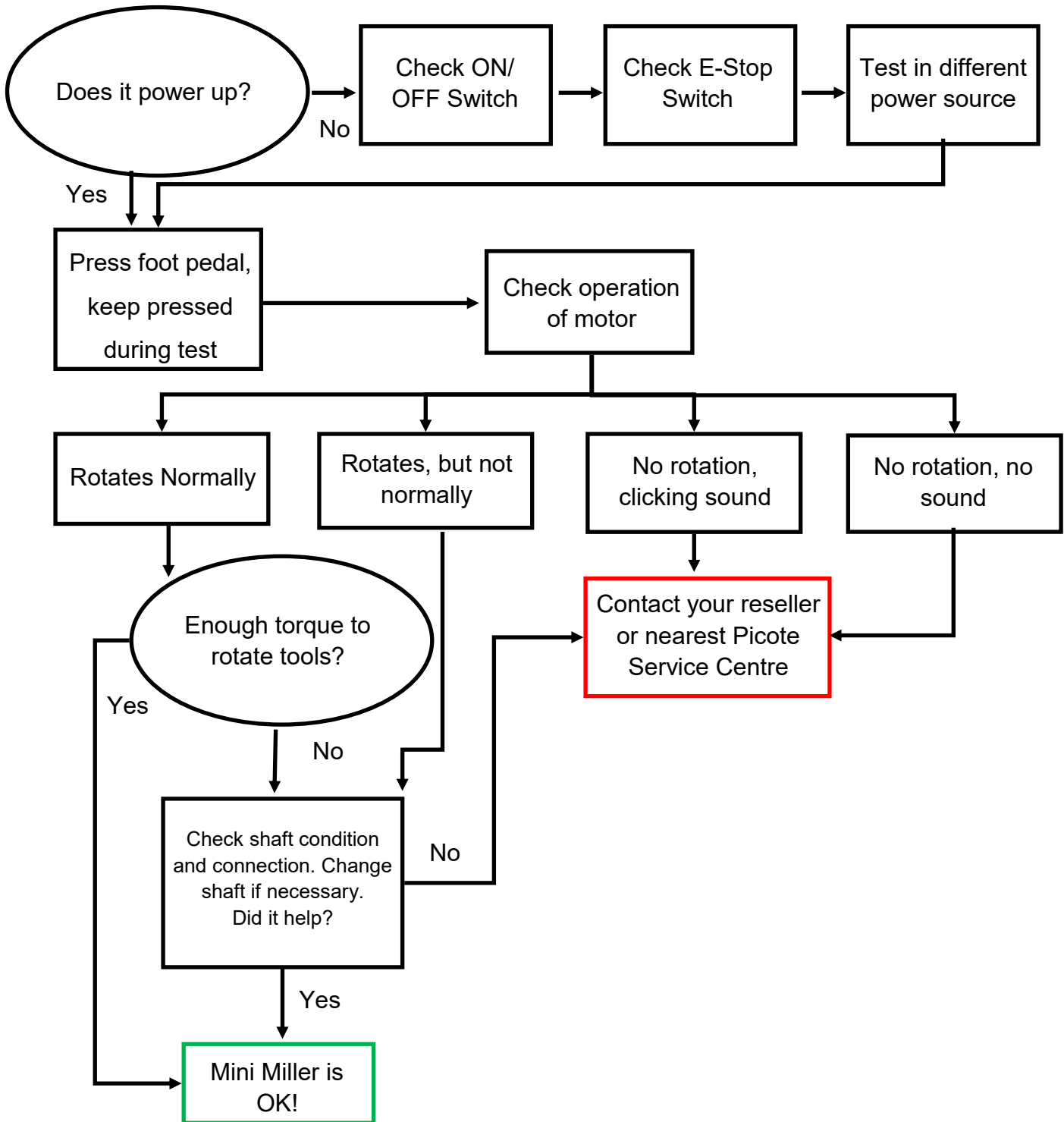

If there is a problem that you cannot resolve with this manual, please consult Spartan Tool or Picote Solutions at claims@picotesolutions.com.



TRAINING CENTERS

- Phoenix, Arizona, USA
- Porvoo, Finland
- Sandhurst, England, UK



Picote is highly recommended to get the most out of your investment.

Certificates are awarded for all certification trainings.

Visit our website at www.picotegroup.com or contact us at training@picotesolutions.com to find out about course offerings, pricing, and scheduling.





For our terms and conditions, including warranty, please visit <https://spartantool.com/pages/terms-and-conditions>. For warranty assistance, please contact us at (800) 435-3866 or customerservice@spartantool.com.

CONTACT US

Spartan Tool LLC
1618 Terminal Road
Niles, MI 49120
800.435.3866
SpartanTool.com



SPARTAN TOOL

FOR TOUGH CUSTOMERS. SINCE 1943.

CONTACT US

Spartan Tool LLC
1618 Terminal Road
Niles, MI 49120
800.435.3866
SpartanTool.com